

VESTABOARD

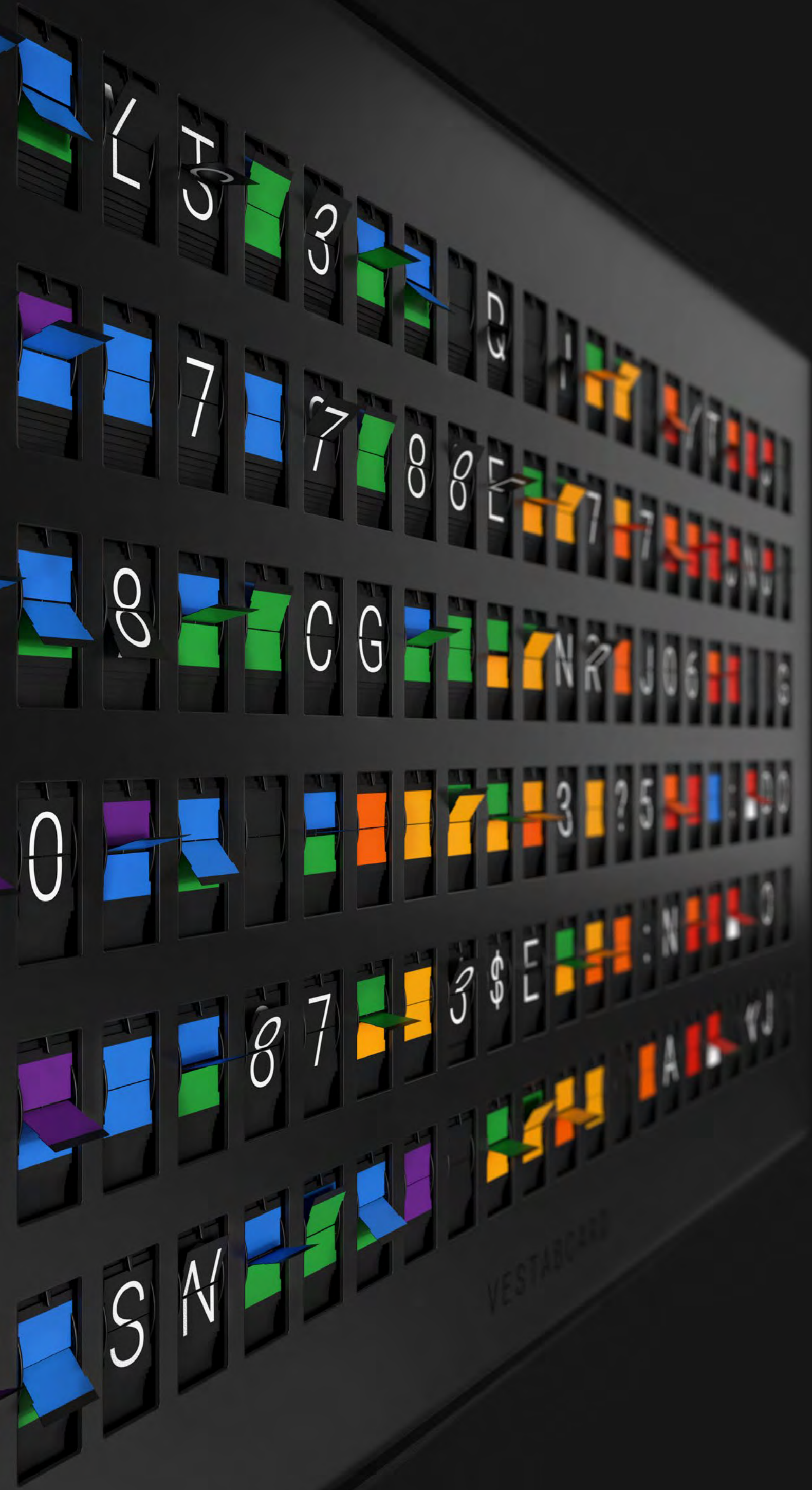

Vestaboard Flagship Specifications and Installation Guide



Black

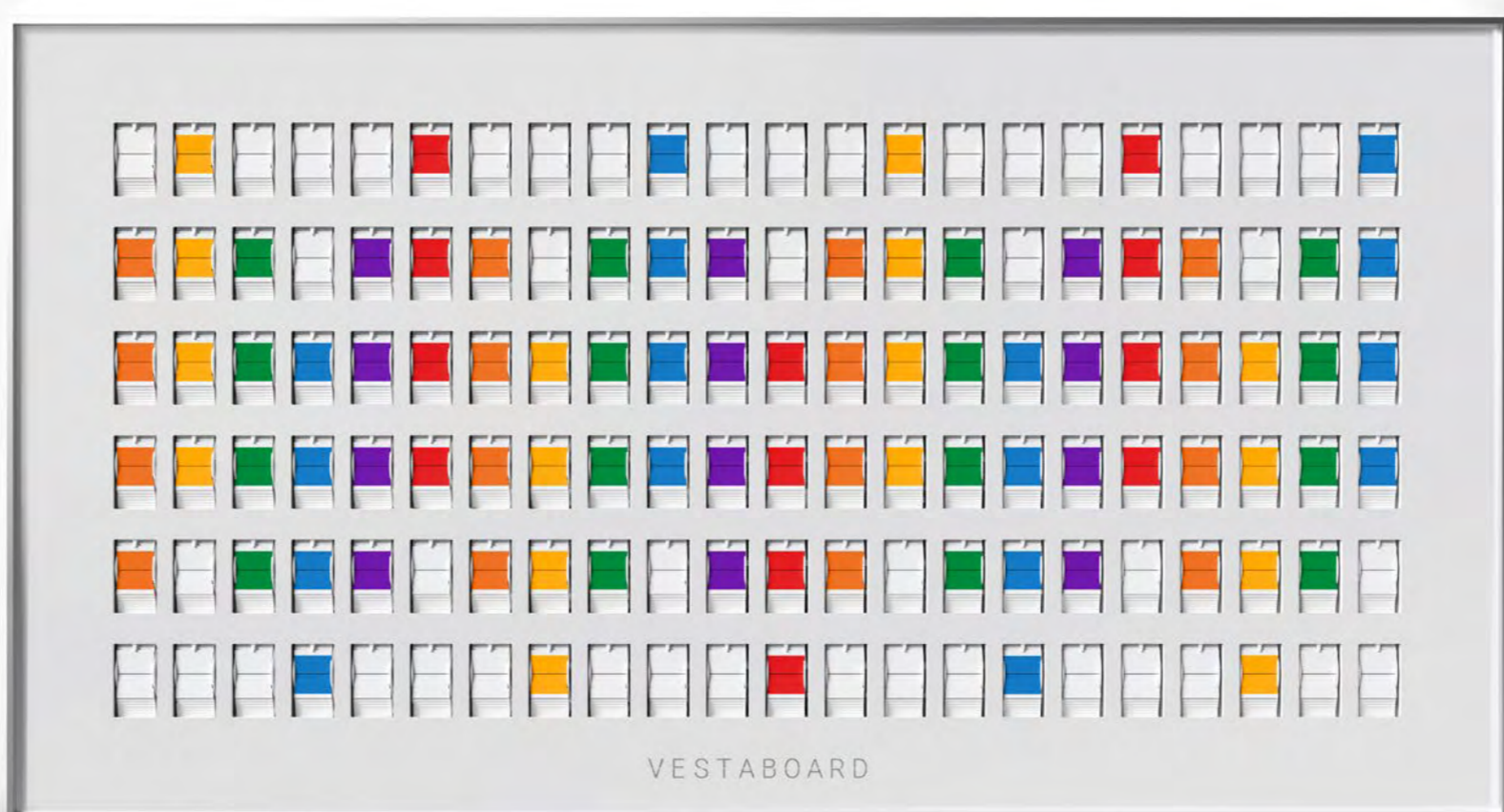

White

Table of Contents

Specifications

Details	5
Components	6

Installation

Power	8
Mounting	9
Pairing	11

Support, Service and Warranty	15
--------------------------------------	-----------

Specifications



Details

Flap Colors

Poppy Red	■	(PMS 485 C)
Orange	■	(PMS 2018 C)
Yellow	■	(PMS 1235 C)
Green	■	(PMS 347 C)
Paris Blue	■	(PMS 2173 C)
Violet	■	(PMS 526 C)
White	□	(White C)
Black	■	(PMS 426 C)

Size

41.2	inches wide	(1046 mm)
22	inches tall	(561 mm)
3.5	inches deep with mount	(89 mm)
3.2	inches deep without mount	(81.5 mm)

Frame

Made from beautifully finished aluminum

Black	■	(RAL 9011 Graphite Black)
White	□	(RAL 9003 Signal White)

Weight

45	pounds without frame	(20.4 kg)
55	pounds with frame	(24.9 kg)

Frame is required but removable for installation and service

Characters

56 alphanumeric characters
 8 color characters (B,W,R,O,Y,G,B,V) Displays
 up to 132 characters at once

Connectivity

802.11 a/b/g/n embedded Wi-Fi / Ethernet port
 Supports 2.4 and 5 GHz networks

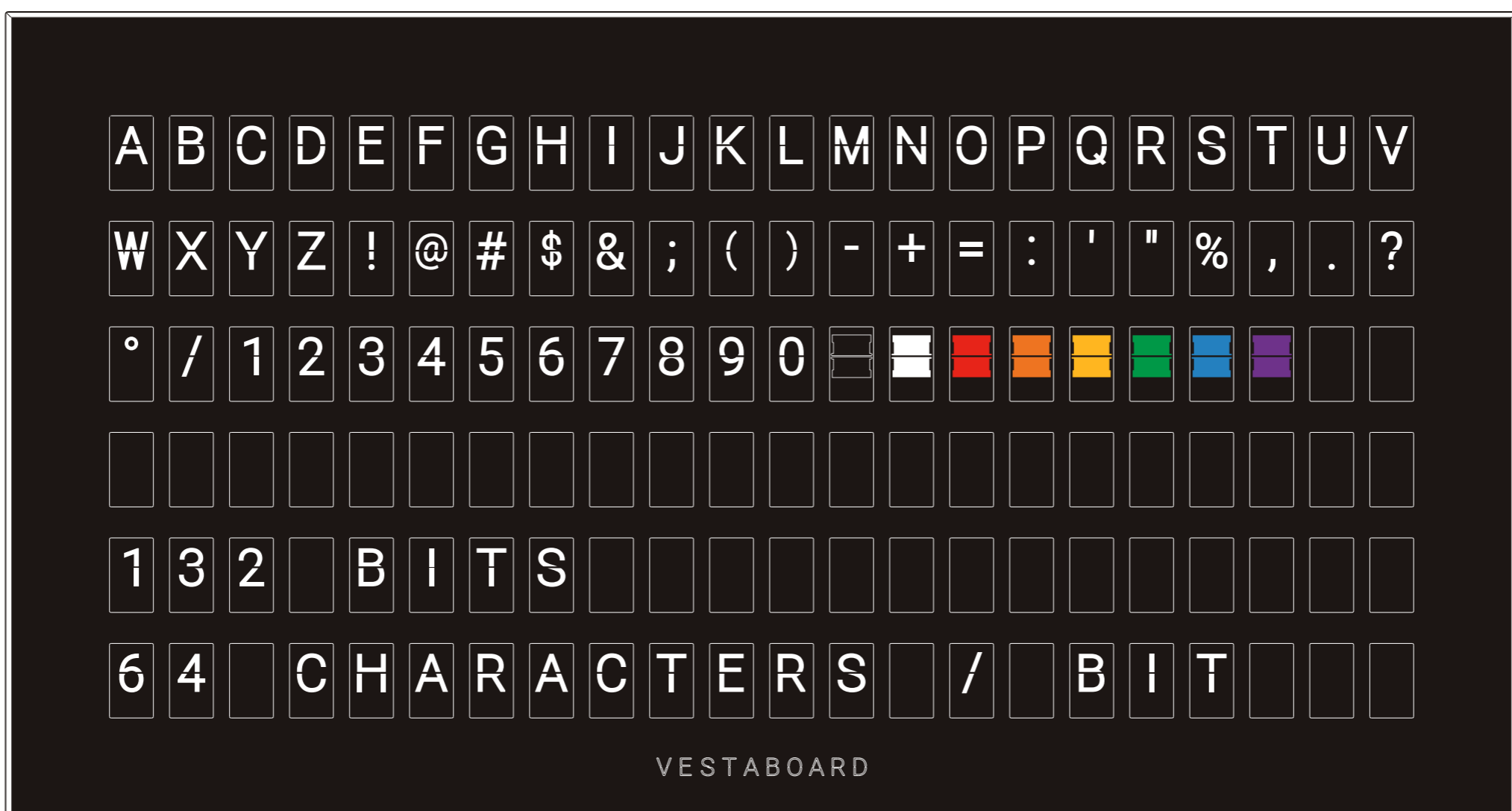

Components

Wall Plate

The included wall plate is secured to the wall. The included and attached brackets (see page 10) easily hook onto the wall plate for easy installation.

Bits

Vestaboard consists of 132 Bits, with each capable of displaying 64 die-cut characters (including letters, symbols, numbers and colors). Each Bit can easily be replaced by hand and without tools, if necessary, by removing the frame.

Characters are visible from over 50 feet (15 m).

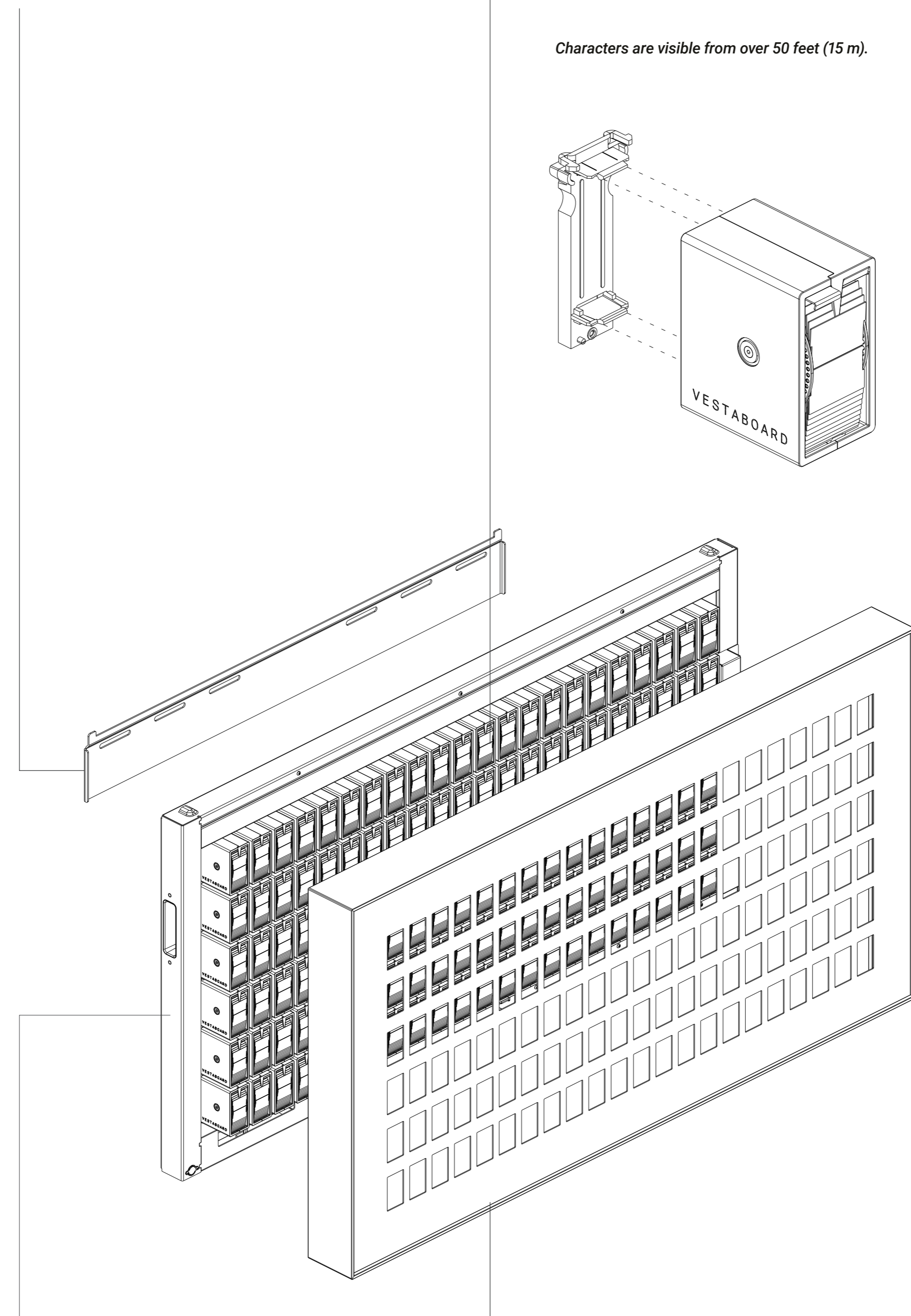
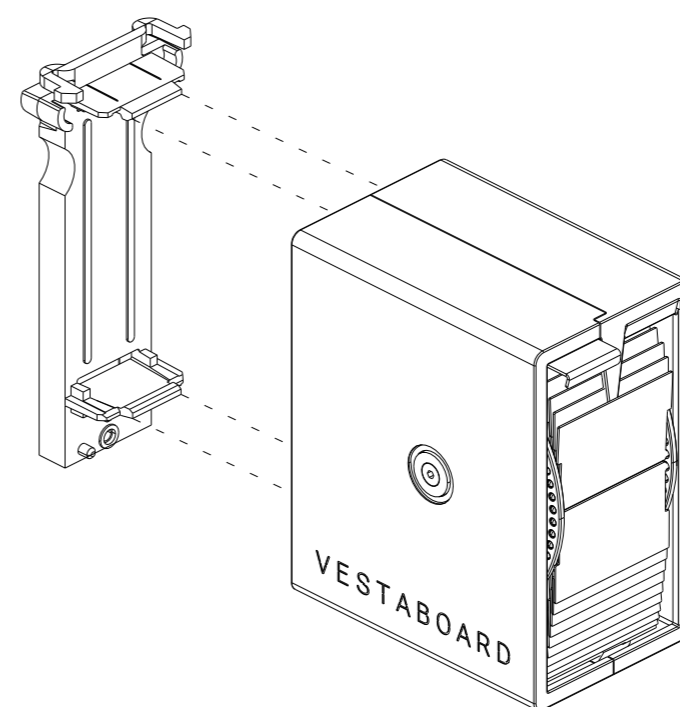

Backplane

The backplane houses all of the electronics, connectivity and power needs of Vestaboard. It also holds all of the Bits.

Frame









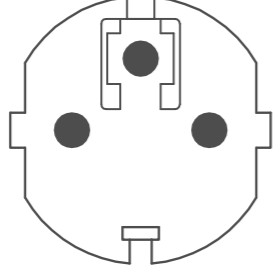

The Vestaboard frame can be removed to access the backplane and Bits if necessary. Your Vestaboard pairing code will not appear if the mask is not properly in place.

Installation

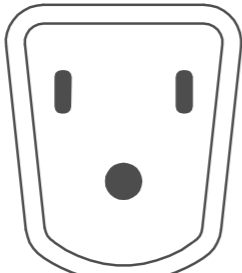

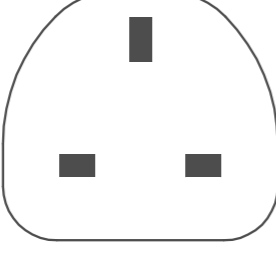
Power

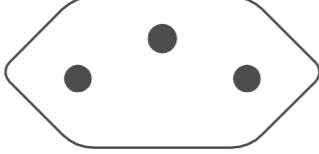
- Powered by a single standard 3-prong plug that supports 100-240V for North America and international power consumption
- Uses 121 watts when updating a message (similar power consumption to an LCD television), and minimal power consumption when idle
- Ships with a 19.7" (50cm) IEC 320 C5 power cable to support concealed wall mount installations
- Vestaboard sells a 8' (2.5m) option in black and white finishes at vestaboard.com/cords

	<p>Type I</p> 
	<p>Type E</p> 
	<p>Type B</p> 
	<p>Type G</p> 
	<p>Type J</p> 

Mounting

Vestaboard cannot be placed upright on a table or surface without an appropriately rated VESA compatible display system, or it is likely to fall over.

We recommend Vestaboard be installed with the included mounting system with a power outlet either behind or below the Vestaboard as seen in the installation video below.



Watch our video walking through the install process.



Download a printable copy of our template specifications.

Recessed Wall Outlet

Behind Vestaboard

For optimal results, we recommend installing a recessed outlet behind the Vestaboard.

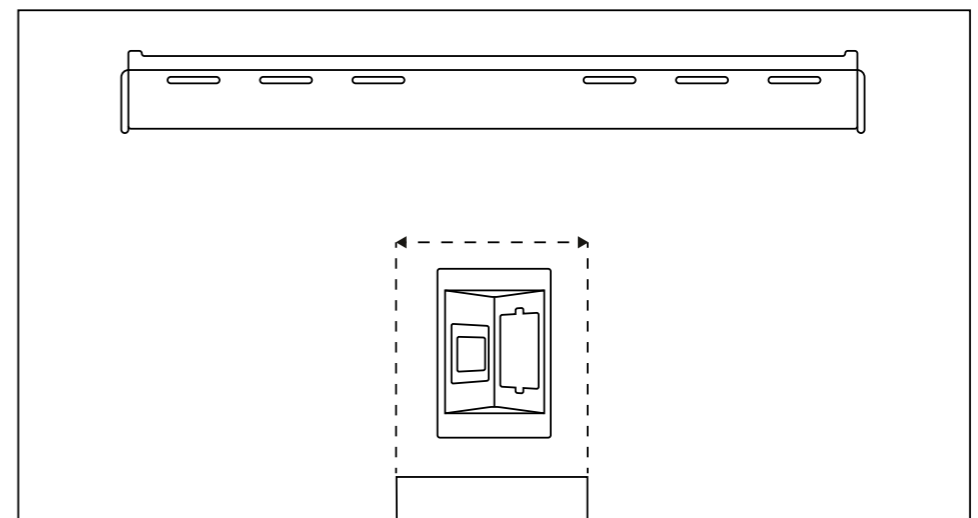

Standard Wall Outlet

Behind Vestaboard

It is also possible to conceal power by placing a standard wall outlet horizontally at the bottom of the Vestaboard as seen.

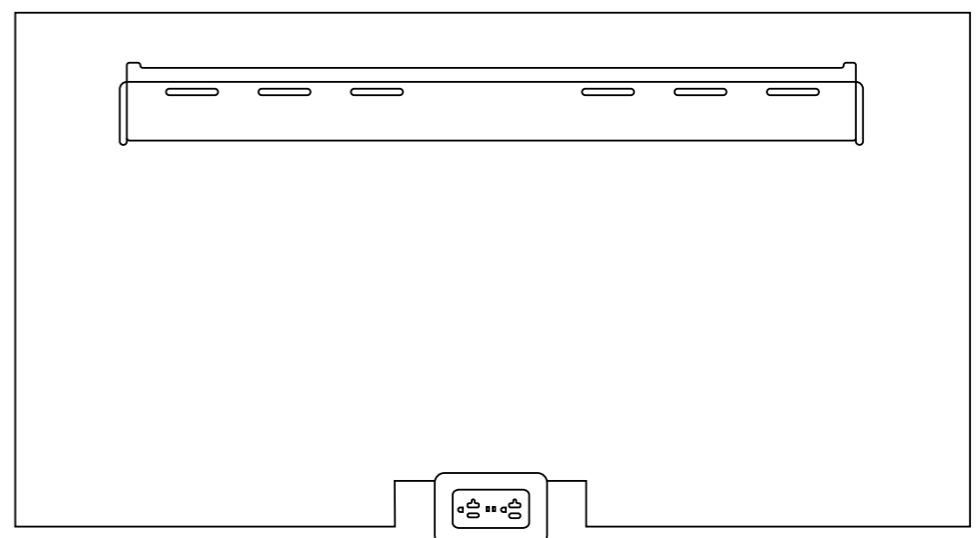

Below Vestaboard

8ft (2.5m) accessory power cables are available for purchase at vestaboard.com/cords.

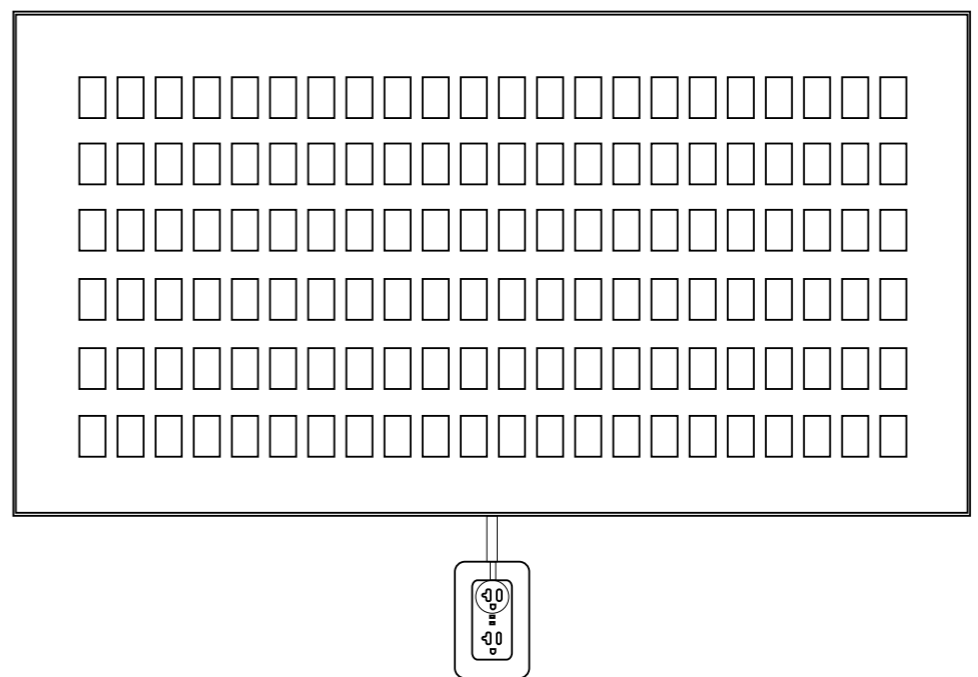

Mounting

Vertical Rails

The vertical rails are pre-attached. They are removable to allow the Vestaboard to be mounted with any 400mm x 400mm VESA compatible mounting system.

Power Jack

Vestaboard supports 110V-240V at 50-60 Hz for North America and International, and will ship with a 19.7" (0.5m) IEC 320 C5 power cable.

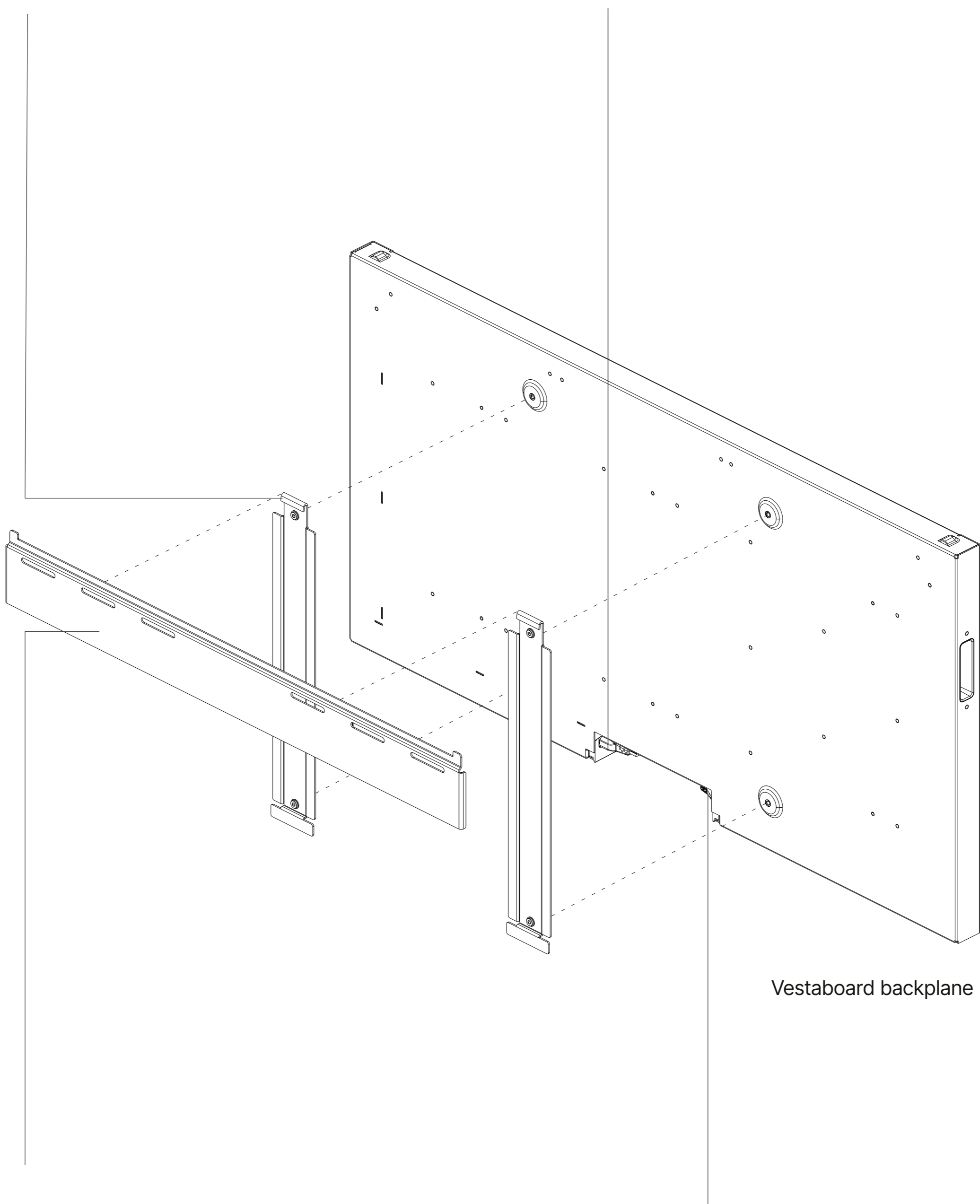

Wall Plate

The included wall plate is secured to the wall. Vestaboard must be properly mounted into a wood stud or concrete wall.

Important - You are responsible for proper installation of the wall plate based on the type of wall. If you are unsure how to mount your Vestaboard, our nationwide network of trained technicians is here to help!

Ethernet Port

Vestaboard works with WiFi with an alternative Ethernet port if desired.

Pairing

1

Create or sign into account

Download the Vestaboard app at vestaboard.com/app and create an account. If you already have an account, simply sign in once the app is installed on your device.



2

Enter pairing code

When powered on for the first time with the frame properly in place, your Vestaboard will boot up with a sequence that ends with a unique 6-character code. The account owner will use this 6-digit code to pair your Vestaboard via the mobile app.

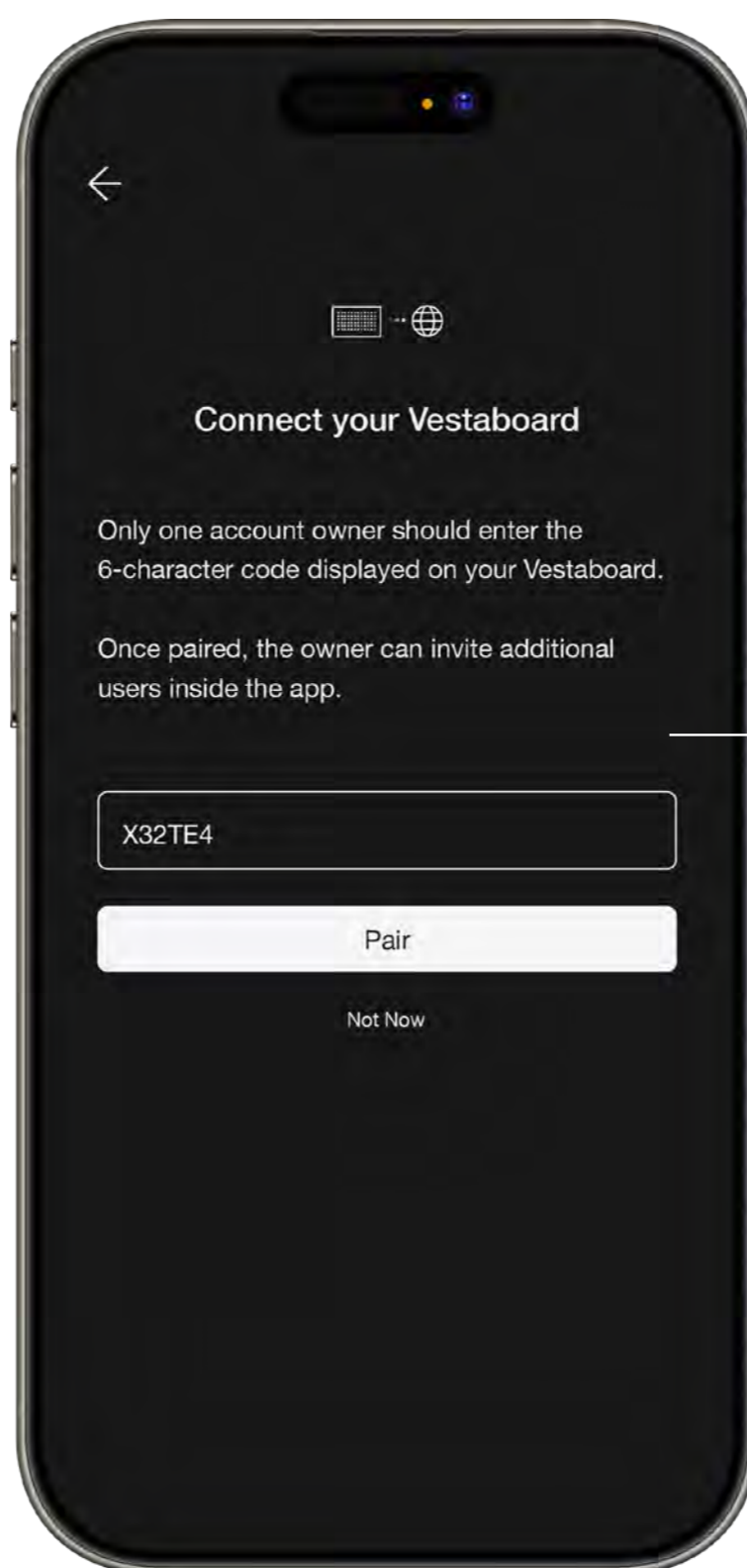

Pairing

3

Connect to a network

From your device, choose either an ethernet or Wi-Fi network connection for your Vestaboard.

If Wi-Fi, your Vestaboard will connect after a hotspot passes the selected Wi-Fi password credentials to your Vestaboard.

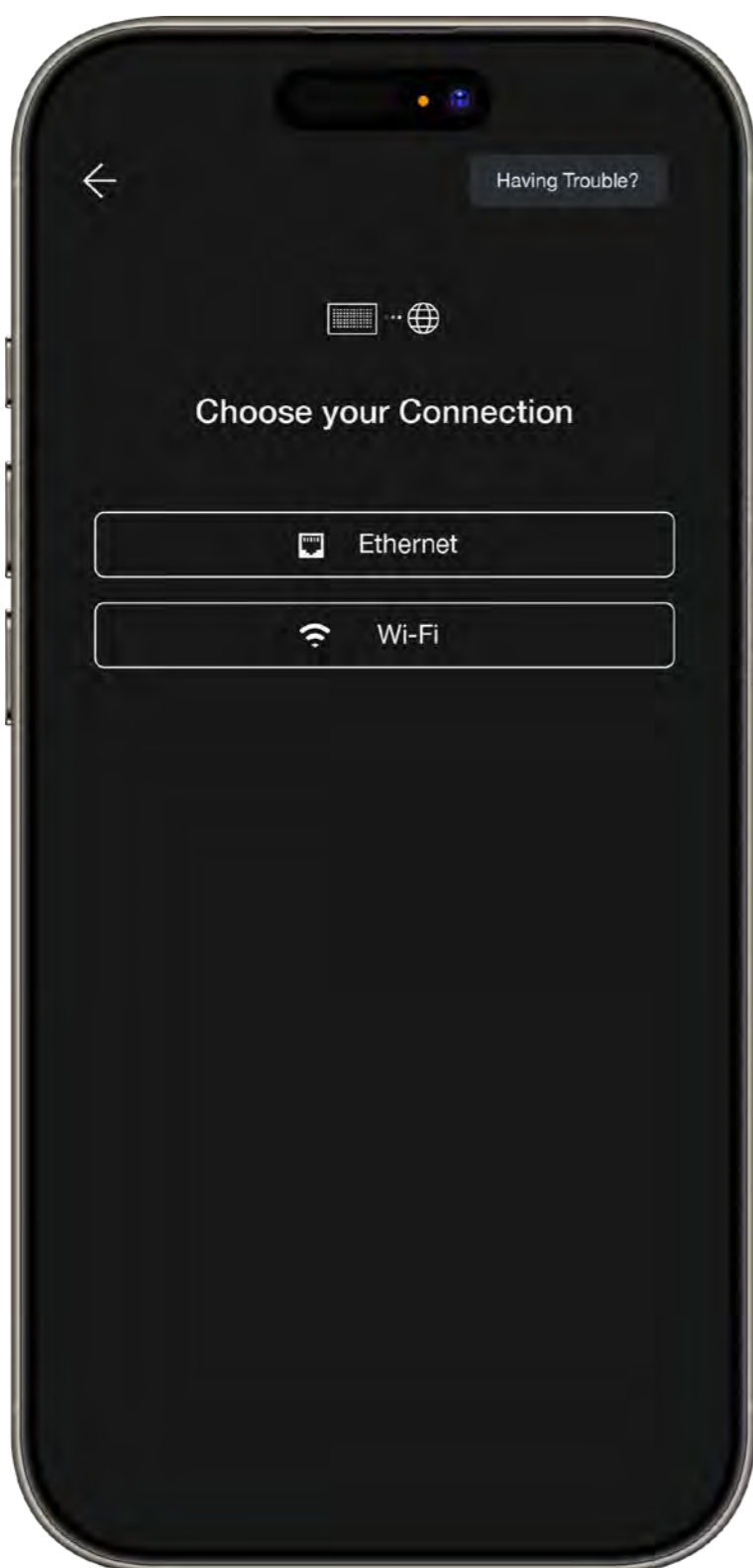

4

Assign a name

The final step before sending your first message is to assign a name to your Vestaboard. Consider naming it after the room or space it is installed in.

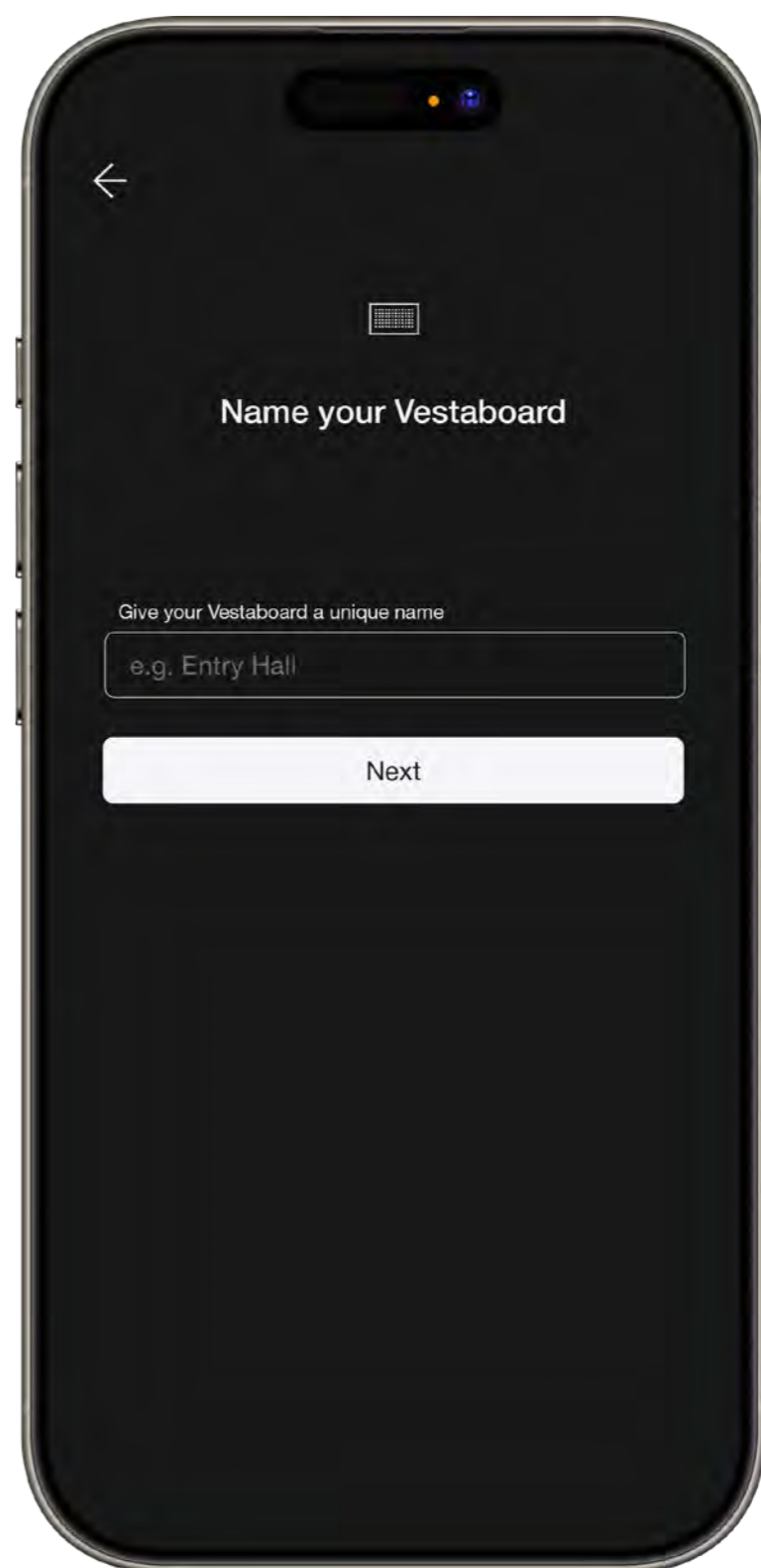

Pairing

5

Send a message

Your Vestaboard is now ready to receive its first message. Send our suggestion or create your own. Then, compose future messages directly from the mobile app or via web.vestaboard.com

6

Share with others

Invite others to manage your Vestaboard inside the app. Share a picture of your Vestaboard in action to support@vestaboard.com or tag us on instagram [@vestaboard](https://www.instagram.com/vestaboard)

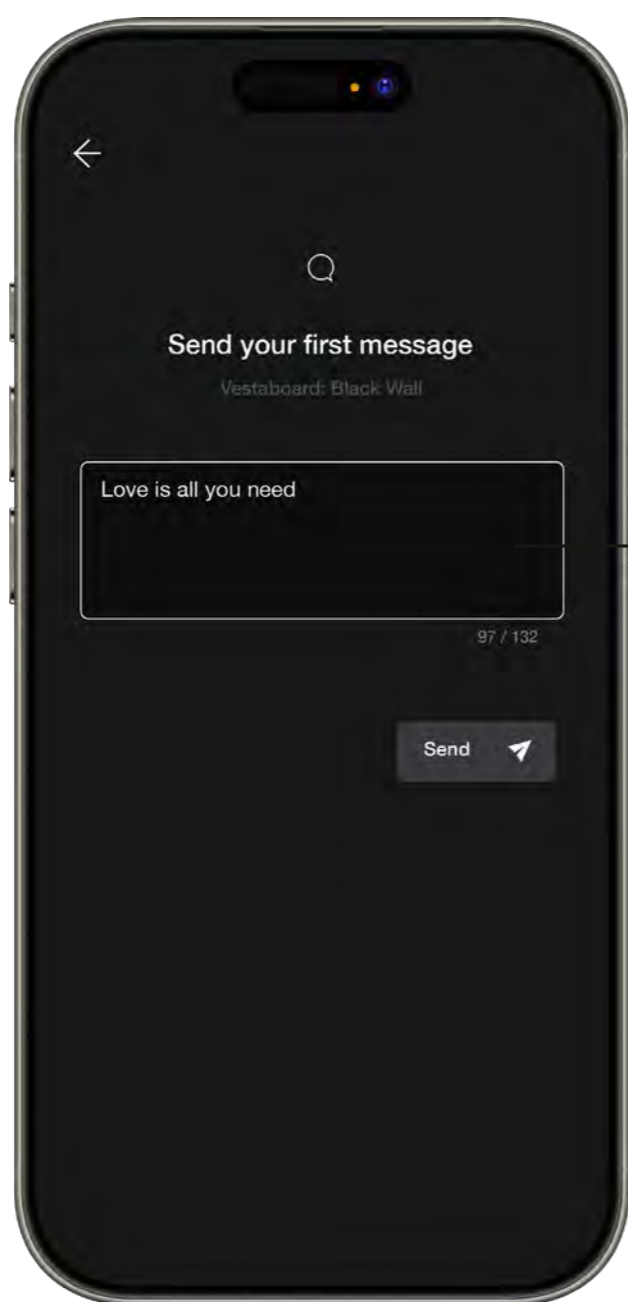

Support, Service and Warranty





Real-Time Support

Whether at home or at work, you'll get fast and friendly support from our in-house team of experts. Vestaboard offers telephone support for the first 90 days. Free web, email and chat support is available for the life of your Vestaboard.

Phone: **+1 615.212.9338**

Email: **support@vestaboard.com**

Support: **vestaboard.com/help**



Professional Installation and Service in United States/Canada

Vestaboard offers a nationwide network of third party installers and service technicians trained and ready to help install your Vestaboard.

Installation includes proper mounting of the Vestaboard in a specified wall, but does not include installation of any recommended electrical outlet.

Learn More: **vestaboard.com/installation**



Included Two-Year Limited Warranty

Your Vestaboard is protected by a limited parts and labor warranty for two years for non-commercial use. In the event that a Bit needs to be replaced, Vestaboard will send a replacement Bit promptly upon receipt of the defective Bit. Our warranty is non-transferable and is limited to the original Vestaboard owner.

Vestaboard extends the Limited Warranty to use cases at home or in small businesses or organizations (defined as organizations or businesses with 50 employees)

For a complete description of the Vestaboard limited warranty, please see:

vestaboard.com/warranty

THE SUN IS
THE SKY IS
IT'S BEAUTIFUL